

#1 18 23 25 37 60
71 72 73 65 70
+ 4x 590.30.196.000,
1x 0472 042175, 0015 060103
+ LAGER
BEARINGS
2x 800.30.019.000, 0625 062034,
1x 490.30.023.000, 0625 062054,
0625 068060, 0625 069050

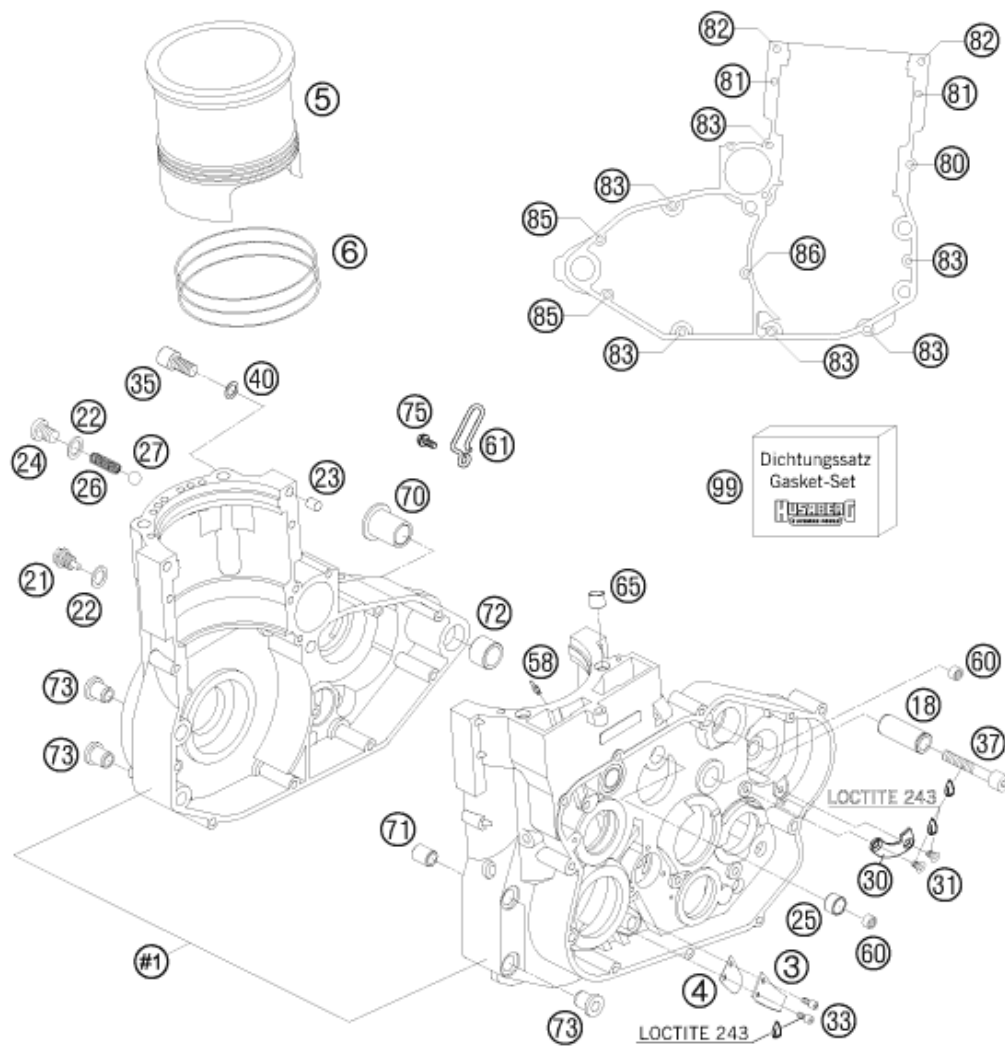

Pos	Part Number	Description	Additional Text	Quantity
1	82030000144	ENGINE CASE CPL. 650 05		1.00
3	80030003050	STOP SHEET MEMBRANE 03		1.00
4	80030003051	MEMBRANE 03		1.00
5	82030005000	CYLINDER LINER 100MM 650 03		1.00
6	0770102020	O-RING 102,00X2,00 VITON 02		3.00
18	59033018000	BUSHING PIN 2000		1.00
21	58030021000	OILDRAIN PLUG W.MAG. M 12X1,5		1.00
22	58038022000	CU-seal ring DIN7603-12X18X1.5		2.00
23	59030023000	dowel sleeve 6x8x11.5		3.00
24	0908120153	threaded plug DIN 908 M12x1.5	DUKE	1.00
25	80040025050	BUSHING 12X15X9,7		1.00
26	80038026000	SPRING OIL PRES.RELIEF HUSA.04		1.00

27	0401100000	BALL D=10 DIN 5401		1.00
30	80033060000	ENGAGEMENT SLEDGE 03		1.00
31	0019050103	INT TORX FLAT HEAD M 5X10 8.8		2.00
33	0912040063	AH SCREW DIN0912-M 4X 6		2.00
35	0912080163	AH SCREW DIN0912-M 8X16		1.00
37	0912060404	AH SCREW DIN0912-M 6X40 A2		1.00
40	58030081000	CU-SEAL RING 8 X 14 X 3		1.00
58	80030058060	OIL JET "60" M4		1.00
60	0618081210	NEEDLE BUSH HK 0810 DIN 618		2.00
61	80031081000	BOW FOR BREATHER HOSE 04		1.00
65	80036085000	DOWEL 10,5X12X10 03		2.00
70	80030170000	DOWEL ENGINE CASE REAR 03		2.00
71	80030071000	DOWL 9X13X15,5 03		1.00
72	80030072000	DOWEL 16,1X22X16 03		1.00
73	80030171000	DOWEL ENGINE CASE FRONT 03		4.00
75	0015050123	HH COLLAR SCREW M 5X12 WS=8		1.00
80	0015060353	HH COLLAR SCREW M 6X35 WS=8	LC4 ADVENTURE	1.00
81	0015060403	HH COLLAR SCREW M 6X40 WS=8	450 SMR	2.00
82	0015060453	HH COLLAR SCREW M 6X45 WS=8	525 SMR	2.00
83	0015060503	HH COLLAR SCREW M 6X50 WS=8		6.00
85	0015060603	HH COLLAR SCREW M 6X60 WS=8		2.00
86	0015060653	HH COLLAR SCREW M 6X65 WS=8		1.00
99	80030099000	GASKET SET 450-650 HUSABERG 04		1.00